

Maximum load rating: 300 lbs

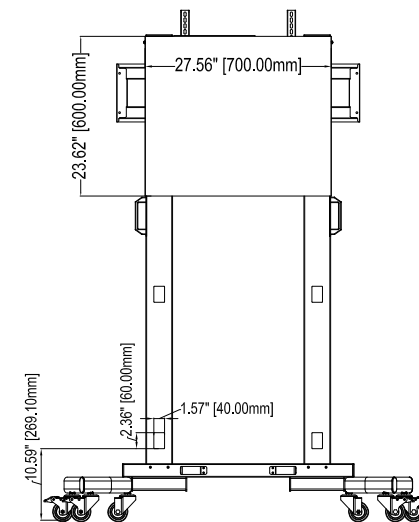

THE INFORMATION CONTAINED IN THIS DRAWING IS THE SOLE PROPERTY OF CRIMSON AV LLC. ANY REPRODUCTION IN PART OR AS A WHOLE WITHOUT THE WRITTEN PERMISSION OF CRIMSON AV LLC IS PROHIBITED

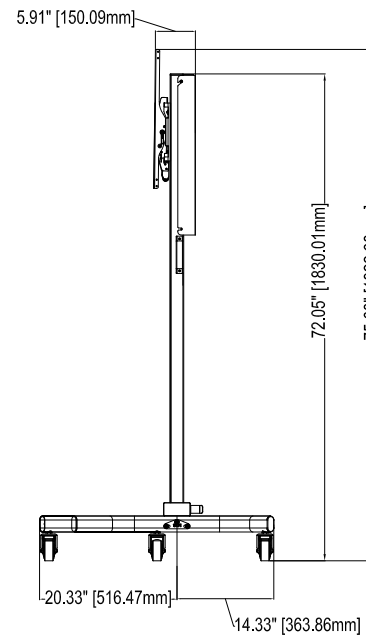
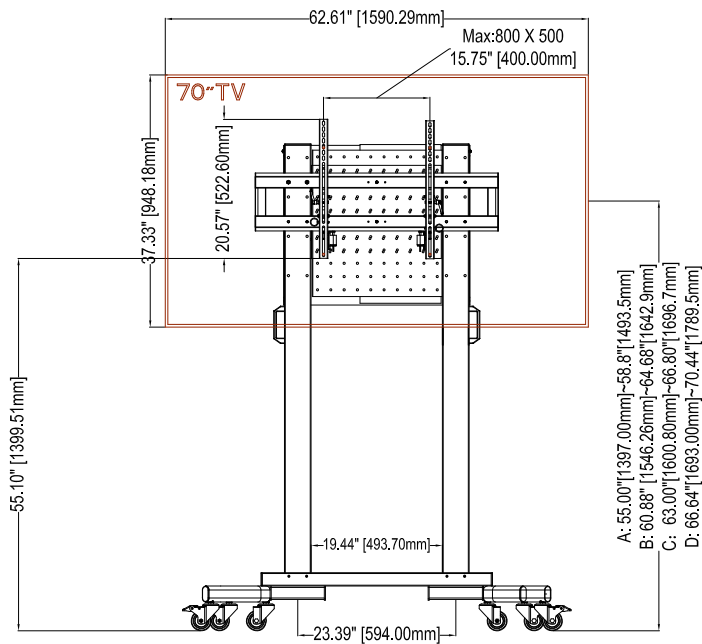
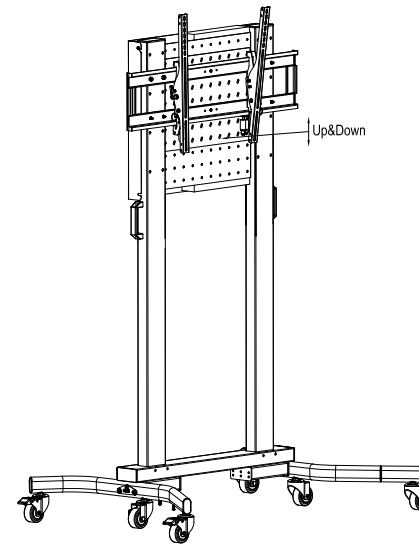
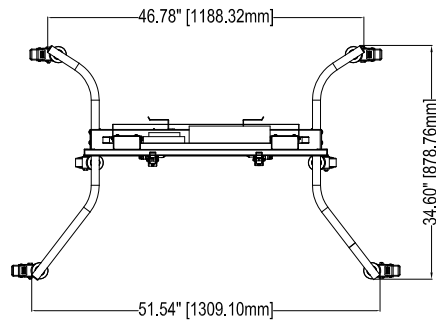

CRIMSON AV LLC.

PRODUCT ORDER NUMBER: M90LS
 PHONE: 1-866-668-6888

Scale=1:1

Crimson AV LLC. www.crimsonav.com	
TITLE:	M90LS
SIZE	DWG.NO. M90LS