

Maximum load rating: 50 lbs

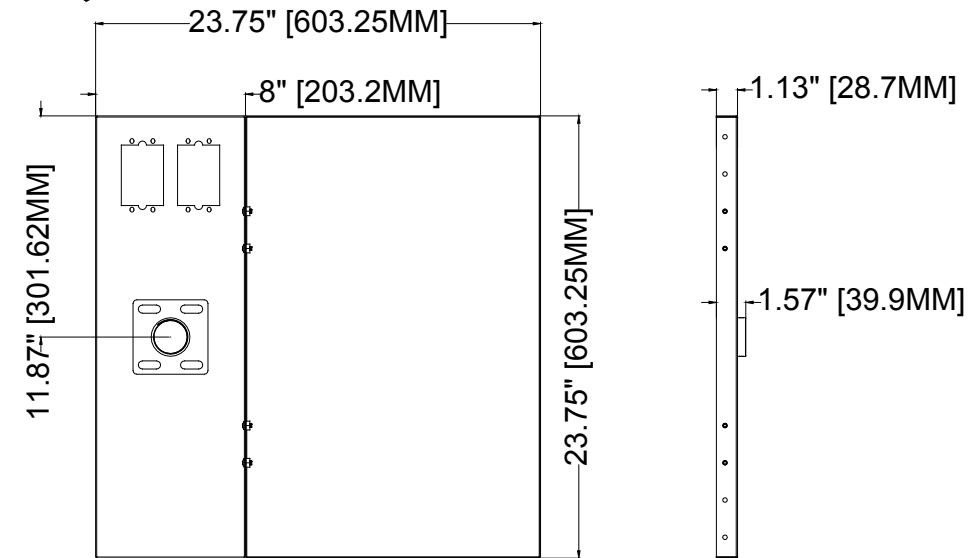

THE INFORMATION CONTAINED IN THIS DRAWING IS THE SOLE PROPERTY OF CRIMSON AV LLC. ANY REPRODUCTION IN PART OR AS A WHOLE WITHOUT THE WRITTEN PERMISSION OF CRIMSON AV LLC IS PROHIBITED

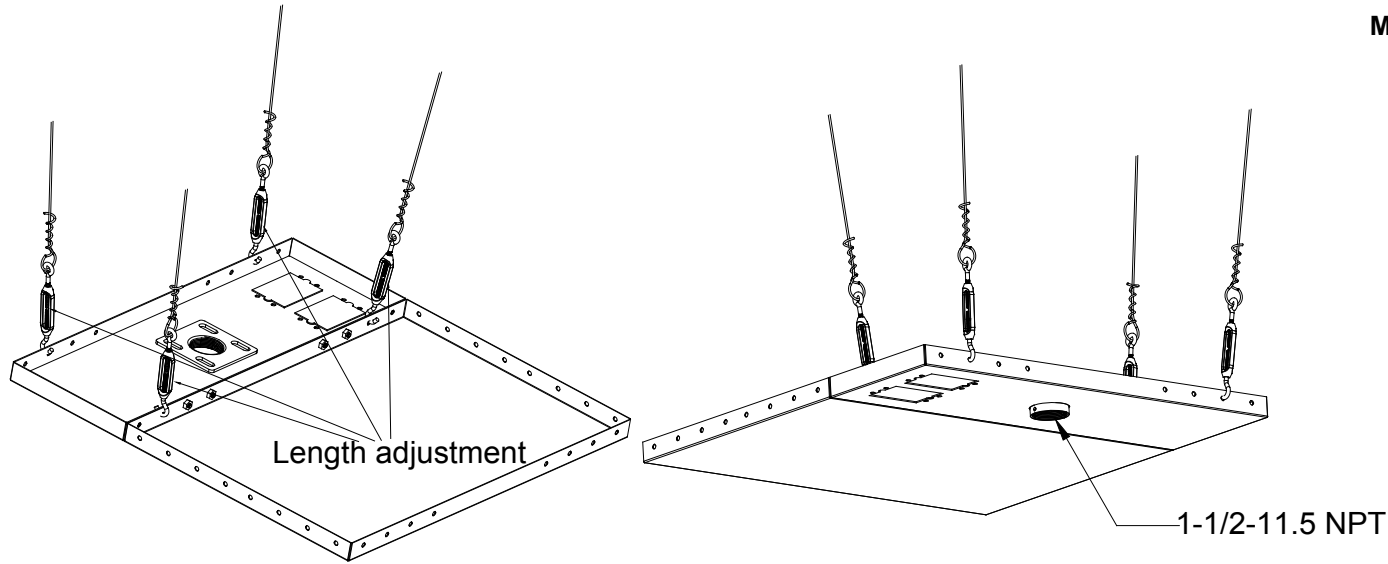

CRIMSON AV LLC.

PRODUCT ORDER NUMBER: **CAS3W**
PHONE: **1-866-668-6888**

Scale=1:1

Crimson AV LLC.
www.crimsonav.com

TITLE:

CAS3W

SIZE
B

DWG.N.O.

CAS3W